

# VST Installation Procedure for Phase II Coaxial EVR Balance Fuel Hoses

Part Number Series: VSTA-EVR, VDV-EVR, VSTAP-EVR and VDVP-EVR



**Vapor Systems Technologies, Inc.**

650 Pleasant Valley Drive  
Springboro, Ohio 45066 (USA)

Toll Free: 1-888-878-4673

Phone: 937-704-9333

Fax: 937-704-9443

www.vsthose.com

## GENERAL INFORMATION

If hanging hardware components are involved in a drive-off or incur other customer abuse, each individual component must be functionally tested prior to customer dispensing activities.

**Figure 1.**

EVR Balance Hanging Hardware Assembly

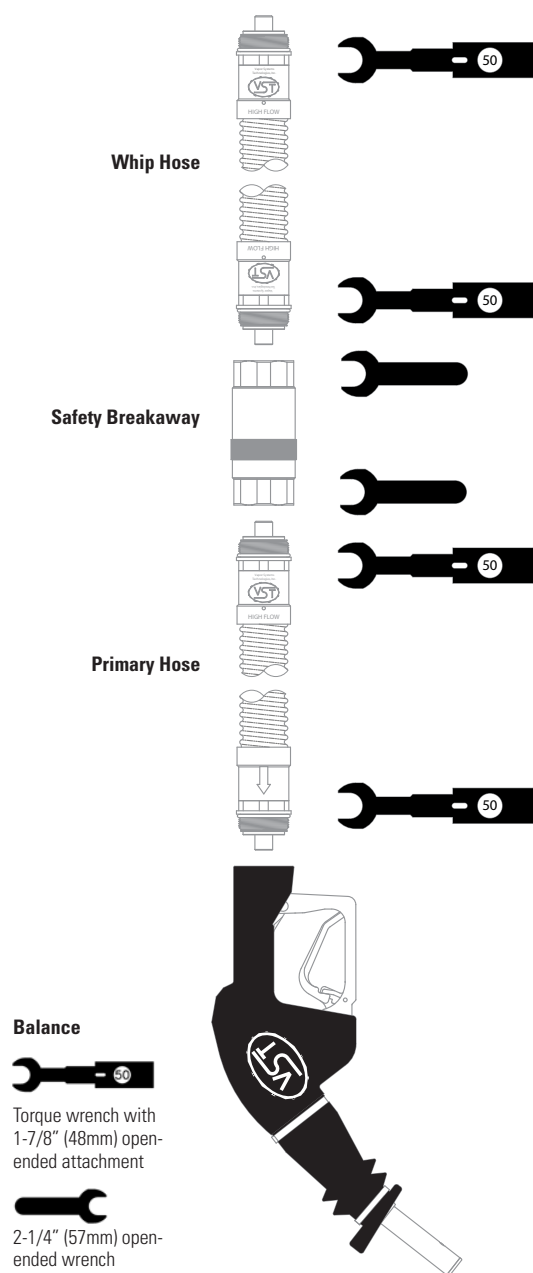

## INSTALLATION PREPARATION

This procedure must be followed to insure leak-proof installation and operation of these hose products.

1. Turn off and tag the power to the dispenser. Dispenser must be de-energized prior to service to avoid personal injury.
2. Barricade work area to block vehicle access to the dispenser.
3. Close the dispenser shear valve prior to removing hanging hardware (hoses, safety breakaways, and nozzles).
4. Drain liquid product from the hanging hardware set into an approved container prior to replacing any hanging hardware components.
5. Remove hanging hardware from the dispenser prior to making replacement component assembly connections. VST recommends connecting the whip hose to the dispenser as the last connection during the hanging hardware assembly.

## INSTALLATION AND FUNCTION TESTS

1. The maximum length of the hose assembly shall not exceed fifteen (15) feet. Lengths greater than fifteen (15) feet are permitted if acceptable to authorities having jurisdiction.
2. Initial inspection:
  - a. Carefully unpack hose from shipping carton.
  - b. Inspect All O-Rings on each end of the hose to determine that they are present and undamaged.
  - c. Inspect hose exterior for any damage.
  - d. Inspect coupling threads for any damage.
3. Lightly lubricate ALL O-Rings on mating connections with petroleum jelly or other suitable lubricant. DO NOT USE pipe dope or thread sealant.
4. Insert the hose coupling into the mating connection and hand tighten.

NOTE Flow direction arrows on whip and primary hoses, where applicable, are indicated on hose coupling cuffs.

5. Tighten all the hose-joint connections to 50 foot-pounds of torque. DO NOT OVER TIGHTEN. Use a torque wrench with an open-end attachment to fit the hose couplings and an open-end wrench to properly tighten coupling connections.

DO NOT USE channel-locks or pliers to tighten hose joints. Proper ft./lb. torque may not be achieved with these tools.

6. Purge air from the system by pumping one-tenth (1/10) to two-tenths (2/10) of a gallon of fuel into an approved container.

Inspect each hose-joint connection for liquid leaks and meter creep. Make proper adjustments at the hose connection if necessary.

7. Check the nozzle shut-off action by dispensing fuel into an approved container at least three times to assure the proper automatic operation of the interlock rod. The fuel flow-rate must be greater than 3 gpm for the automatic shut-off mechanism to operate.

To test, operate the nozzle and submerge the spout tip in fuel until the fuel level covers the vent hole. The main valve of the nozzle automatically shuts off when the liquid covers the vent hole at the end of the spout. The nozzle is not designed to operate on gravity flow. The hold-open latch will disengage automatically when liquid covers the vent hole in the spout. Verify that the fuel flow stops when the nozzle collection sleeve is decompressed (e.g. interlock rod is disengaged). To test that the fuel flow stops, dispense some fuel into an approved container. Slowly remove the nozzle from the container while dispensing fuel. Fuel flow should stop when the nozzle collection sleeve is fully decompressed.

8. Measure the resistance between the dispenser outlet casting and the tip of the nozzle spout. Use an electronic multimeter set on the high range of the ohmmeter function. Resistance should not indicate more than 70,000 ohms per foot of hose. Example: The measured resistance for a 12-foot hose must not exceed 840,000 ohms (840 kilohms)

### PROCEDURE FOR POSITIONING THE LIQUID REMOVAL DEVICE

This procedure must be followed to insure proper positioning for the liquid-removal device in Part Number Series: VDV-EVR and VDVP-EVR (See Figure 2).

1. After installing the VST hanging hardware, hold the nozzle straight out from the dispenser so that the compressed bellows is 48 inches away from the front face of the dispenser (simulate when the bellows is compressed in the filler neck of a vehicle) and the spout tip of the nozzle is 30 inches above the pavement. The nozzle spout is to be at a 30-degree angle above the horizontal plane.
2. When the hose and nozzle are held in position as shown in Figure 2, the factory installed liquid-removal device indicator-mark (striped line) on the vapor hose must be located:
  - In the bottom of the loop section within the tolerance range.
  - The allowable tolerance range is 3 inches left or right of the 6:00 o'clock position (lowest point of the loop) as measured along the center line of the hose

If the liquid-removal device indicator-mark is not located within the tolerance range, the installer must choose one of the following options:

- Adjust the hose retractor (if installed)
- Use a different length whip hose
- Use a different length primary hose

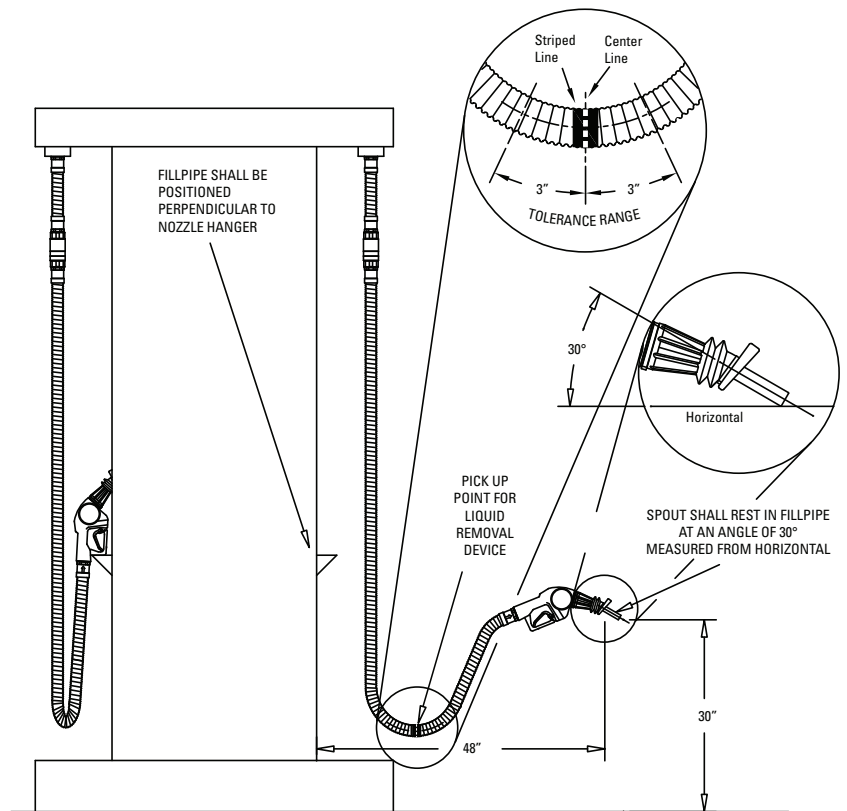

**Figure 2.** Procedure For Positioning the Liquid Removal Device

### IMPORTANT

It is the installing technician's responsibility to insure that the properly sized and marked hanging hardware is installed at the dispenser. Failure to properly install and locate the liquid removal device may reduce the effectiveness of the product in application resulting in outer hose liquid blockage and failure of the liquid removal test procedure.

### MAINTENANCE

Inspect hoses regularly for damage, loose connections, leaks, kinks, blisters, bulges, flattened areas, soft spots, or any cuts/gouges deep enough to expose the reinforcement beneath the hose cover. Replace as necessary. Subject to customer abuse, hoses should be replaced when damaged.

The hose is designed and constructed to give lasting service if properly handled and maintained. If for any reason it should need attention, contact your VST distributor for proper disposition.

### NOTE

Due to abuse, misuse, changing gasoline formulas, variation in maintenance practices, environmental conditions, and/or conditions beyond the manufacturer's control, dispensing equipment may need replacement before five (5) years. Inspections and proper maintenance procedures should be followed by the station manager to determine if replacement is required before five (5) years.

### WARNING

Unauthorized rebuilding or modifying of hoses voids **ALL** approvals and warranties. VST products must be used in compliance with applicable federal, state and local laws and regulations.