

VST Installation Procedure for Phase II Coaxial EVR Balance Safety Breakaway Devices

Reattachable Breakaway Part Number Series: VSTA-EVR-SBKA



Vapor Systems Technologies, Inc.

650 Pleasant Valley Drive
Springboro, Ohio 45066 (USA)

Toll Free: 1-888-878-4673

Phone: 937-704-9333

Fax: 937-704-9443

www.vsthose.com

APPLICATION

These VST Safety Breakaway devices are intended to prevent damage to the dispenser and hose in the event of a vehicle drive off. These devices separate at pull forces up to 350 lbs. Determine that 350 lbs. pull force will not damage the dispenser. After verifying that the dispenser is securely bolted to the island, it can be tested by using a spring scale and a length of rope. The rope must be connected at the dispenser outlet casting, which may require a threaded bushing with a hole for attaching the rope. Attach the scale to the rope and pull to 350 lbs. in several directions. Be sure to avoid damaging the dispenser.

NOTE:

- The whip hose **ALWAYS** attaches to the dispenser. If a retractor is being used, the retractor clamp **MUST** be between the breakaway and dispenser.
- VST hoses are made to withstand 350 pounds tensile pull without damage. If another brand of hose is present at the dispenser, VST recommends that you contact the hose manufacturer regarding the compatibility with this breakaway device.

General Information

If hanging hardware components are involved in a drive-off or incur other customer abuse, each individual component must be functionally tested prior to customer dispensing activities.

Installation Preparation

These procedures must be followed to ensure leak-proof installation and operation of these safety breakaway products.

- Turn off and tag the power to the dispenser. Dispenser must be de-energized prior to service to avoid personal injury.
- Barricade work area to block vehicle access to the dispenser.
- Close dispenser shear valve prior to performing any service work with the hanging hardware (hoses, safety breakaways, and nozzles).
- Drain liquid product from the hanging hardware set into an approved container prior to replacing any hanging hardware component.

Figure 1.

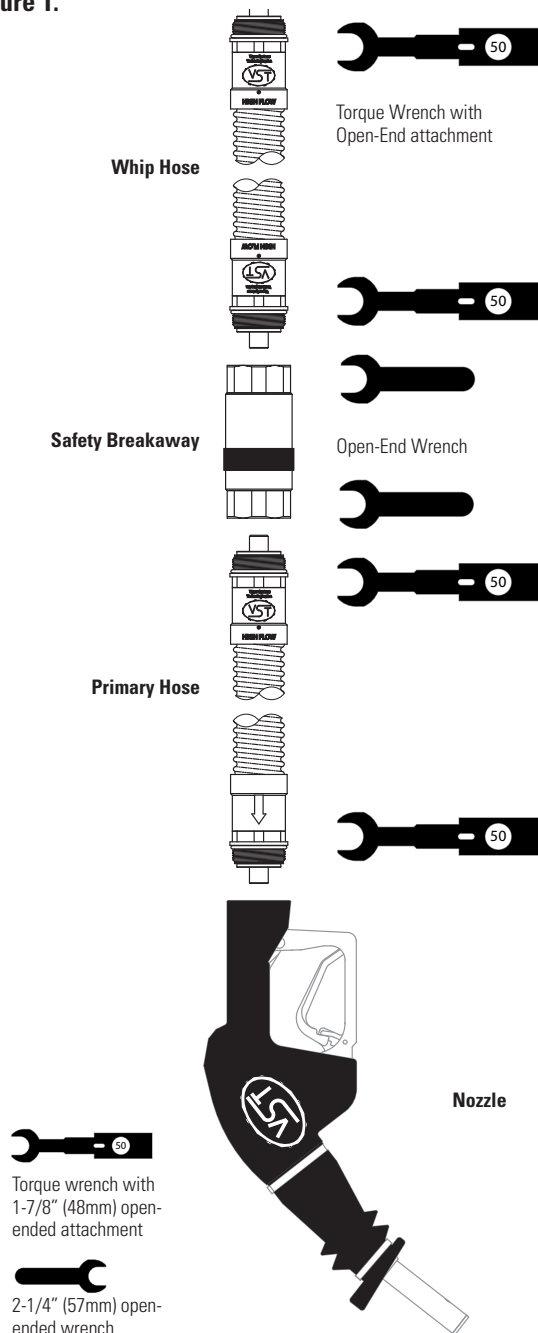

VST Installation Procedure for Phase II Coaxial EVR Balance Safety Breakaway Devices

Reattachable Breakaway Part Number Series: VSTA-EVR-SBKA

5. For the installation of a new breakaway, remove hanging hardware from the dispenser prior to making replacement component assembly connections. VST recommends connecting the whip hose to dispenser as the last connection during hanging hardware assembly.

Installation and Function Tests

1. Initial inspection:
 - a. Carefully unpack safety breakaway from shipping carton.
 - b. Inspect safety breakaway for any damage to threads, O-rings, exterior, etc.
2. Lightly lubricate **ALL** O-rings on mating connections with petroleum jelly or other suitable lubricant. **DO NOT USE** pipe dope or thread sealant.
3. Attach breakaway on mating connection and tighten by hand. **NOTE FLOW DIRECTION ARROW** (where applicable). Use the hex on the breakaway body closest to the connection to tighten. **DO NOT USE** the breakaway body to tighten the unit.
4. Tighten breakaway connection to 50 foot-pounds of torque. **DO NOT OVER TIGHTEN.** Use the hex on the breakaway body closest to the connection to tighten. Use a torque wrench with an open-end attachment to fit the hose couplings and an open-end wrench to properly tighten breakaway connections. **DO NOT USE** channel-locks or pliers to tighten connections. Proper ft./lb. torque may not be achieved with these tools.
5. Purge air from the system by pumping one-tenth (1/10) to two-tenths (2/10) of a gallon of fuel into an approved container. Inspect each hose joint connection for liquid leaks and make proper adjustments if necessary. Checking for meter creep will verify the integrity of the connections. After dispensing the fuel, release the lever and move components around and/or gently shake the hose and verify if the displayed amount on the dispenser changes. If meter creep is experienced, check all components and replace as necessary.
6. Check the nozzle shut-off action by dispensing fuel into an approved container at least three times to assure proper automatic operation of the interlock rod. The fuel flow-rate must be greater than 3 gpm for the automatic shut-off mechanism to operate.

To test, operate the nozzle and submerge the spout tip in fuel until the fuel level covers the vent hole. The main valve of the

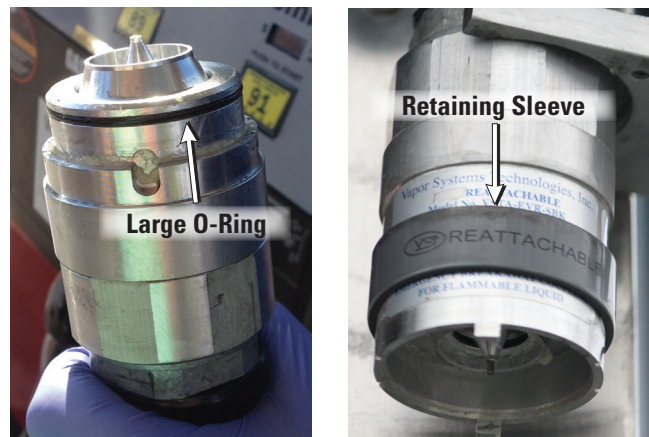

Figure 2: Check each half for damage

nozzle automatically shuts off when liquid covers the vent hole at the end of the spout. The nozzle is not designed to operate on gravity flow. The hold-open latch will disengage automatically when liquid covers the vent hole in the spout. Verify that the fuel flow stops when the nozzle collection sleeve is decompressed (e.g. interlock rod is disengaged). Slowly remove the nozzle from the container while dispensing fuel. Fuel flow should stop when the nozzle collection sleeve is fully decompressed.

7. Measure the resistance between the dispenser outlet casting and the tip of the nozzle spout. Use an electronic multimeter set on the high range of the ohmmeter function. Resistance should not indicate more than 70,000 ohms per foot of hose. Example: The measured resistance for a 12-foot hose must not exceed 840,000 ohms (840 kilohms).

BREAKAWAY REATTACHMENT PROCEDURE

The VSTA-EVR-SBKA Safety Breakaway may be reconnected with the use of the VST Breakaway Assembly Tool (VST-BAT-100).

BREAKAWAY REATTACHMENT PROCEDURE

1. Follow **INSTALLATION PREPARATION** steps 1-4.
2. Inspect both safety breakaway halves for damage that may have occurred during separation. Include looking for external damage to the product and missing alignment pin, etc. See **Figures 2 and 3. If damage or missing parts are detected, replace with new product.** Ensure that the retaining sleeve is placed on the breakaway half connected to the whip hose before reassembly.

VST Installation Procedure for Phase II Coaxial EVR Balance Safety Breakaway Devices

Reattachable Breakaway Part Number Series: VSTA-EVR-SBKA

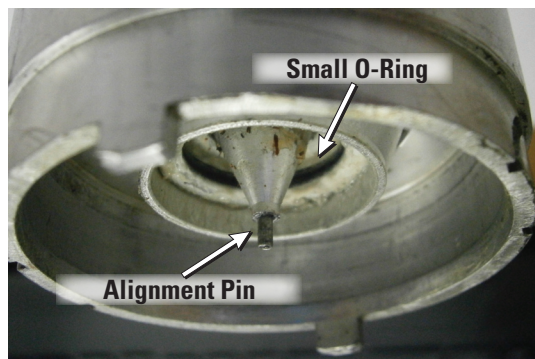

Figure 3: Check for Alignment Pin

3. Prior to reassembling, be sure the mating parts are undamaged and clean.
4. Replace all O-rings with those provided in the repair kit (VST-BRK-100).
 - a. Lightly lubricate the O-rings on mating connections with petroleum jelly or other suitable lubricant. **DO NOT USE** pipe dope or thread sealant.
 - b. Use the large O-ring provided in the repair kit to replace the outer O-ring on the curb hose side of the breakaway. See **Figure 5**.
 - c. Use the small O-ring provided in the repair kit to replace the inner O-ring on the whip side of the breakaway. Use a plastic pick provided in the kit to remove the old O-ring. See **Figure 3**.
5. Apply a liberal amount of lithium grease provided in the repair kit (VST-BRK-100) completely around the mating diameter surface of the curb hose side of the breakaway. The grease will need to cover the entire surface that will slide into the mating end of the breakaway. See **Figure 5**. **DO NOT USE** pipe dope or thread sealant.
6. Utilize the VST Breakaway Assembly Tool (VST-BAT-100) with the appropriate reassembly plates to reassemble the breakaway. The tool is used to provide appropriate leverage for the ease of reassembly of the breakaway and to secure the breakaway during replacement of the shear washers. This can be done without disassembling the hoses from the breakaway halves.
7. Press the button on the Breakaway Assembly Tool to spread the end clamps apart to allow the two separated breakaway halves

to fit between the top and bottom clamps. Slide the top clamp of the VST Breakaway Assembly Tool behind the hex on the breakaway half connected to the whip hose. See **Figure 4**.

8. Slide the separated bottom half of the breakaway (with curb hose and nozzle attached) onto the bottom clamp of the VST Breakaway Assembly Tool. Align the shear ring grooves away from the reassembly tool for ease of insertion of the shear washers. See **Figure 4**.
9. Slowly squeeze the VST Breakaway Assembly Tool trigger to bring the breakaway halves together.
10. Carefully align the two breakaway halves. Place the alignment pin from the breakaway upper half into the hole of the inner poppet on the lower half of the breakaway



Figure 4: Attach Reassembly Tool

CAUTION: Reconnection can cause a small amount of gasoline to leak out of the breakaway. A towel wrapped loosely around the breakaway can help to minimize spills.

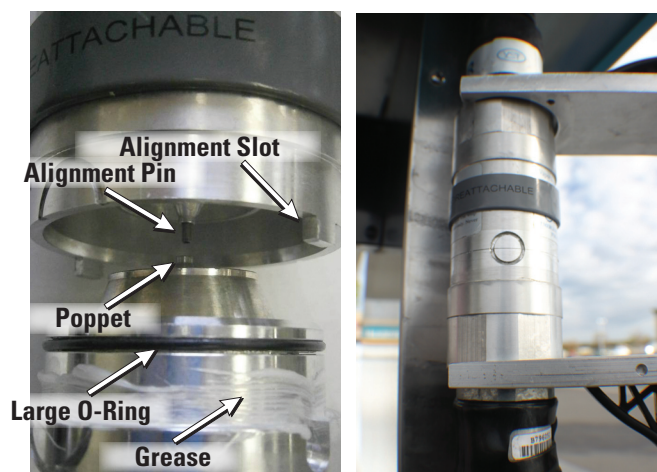

Figure 5: Align Poppet Pin from upper to lower half of breakaway and finish alignment

VST Installation Procedure for Phase II Coaxial EVR Balance Safety Breakaway Devices

Reattachable Breakaway Part Number Series: VSTA-EVR-SBKA



Vapor Systems Technologies, Inc.

650 Pleasant Valley Drive
Springboro, Ohio 45066 (USA)

Toll Free: 1-888-878-4673

Phone: 937-704-9333

Fax: 937-704-9443

www.vsthose.com

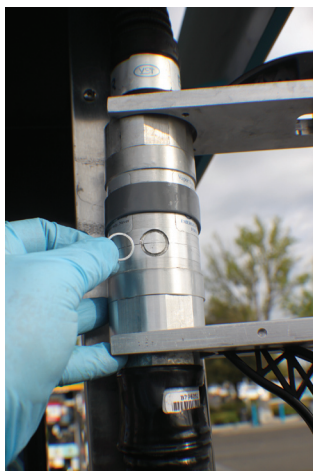

Figure 6: Add Shear Washer



Figure 7: Remove Grease



**Figure 8: Reposition
Retaining Sleeve**



**Figure 9: Verify
Connection Integrity**

that is connected to the nozzle end. Continue squeezing the trigger of the VST Breakaway Assembly Tool while guiding the alignment slots together to finish reassembly. See **Figure 5**.

NOTE: Once the two breakaway halves come together close enough for placement of the shear washers, do not squeeze the tool trigger any further. Unnecessary pressure on the tool could damage or break the tool.

11. Once the two aligned halves are together place one shear washer into each of the shear washer grooves (2 total) from the repair kit (VST-BRK-100). See **Figure 6**. Ensure that the shear washer is completely seated into the groove before moving the retaining sleeve into place. See **Figure 7**. Wipe off excess grease after installation of the shear rings.
12. After the two breakaway halves are reattached, remove the Breakaway Assembly Tool (press the button on the tool to allow the plates to release). Reposition the retaining sleeve to the groove between the two halves of the breakaway. See **Figure 8**. Give the reassembled breakaway a strong pull to verify that it is properly connected. See **Figure 9**.
13. If successful, follow the **Installation and Functional Tests** steps 5 – 7 in this document.

MAINTENANCE

Inspect safety breakaways regularly for damage, loose connections or leaks. Replace as necessary. Subject to customer abuse, safety breakaway should be replaced when damaged.

The safety breakaway is designed and constructed to give lasting service if properly handled and maintained. If for any reason it should need attention, contact your VST distributor for proper disposition.

NOTE: Due to abuse, misuse, changing gasoline formulas, variation in maintenance practices, environmental conditions and/or conditions beyond the manufacturer's control, dispensing equipment may need replacement before five (5) years. Inspections and proper maintenance procedures should be followed by the station manager to determine if replacement is required before five (5) years.

WARNING

Unauthorized rebuilding or modifying of safety breakaways voids ALL approvals and warranties.

VST products must be used in compliance with applicable federal, state and local laws and regulations.

VST Installation Procedure for Phase II Coaxial EVR Balance Safety Breakaway Devices

NON-Reattachable Breakaway Part Number Series: VSTA-EVR



Vapor Systems Technologies, Inc.

650 Pleasant Valley Drive
Springboro, Ohio 45066 (USA)

Toll Free: 1-888-878-4673

Phone: 937-704-9333

Fax: 937-704-9443

www.vsthose.com

Figure 1.

EVR Balance Hanging Hardware Assembly

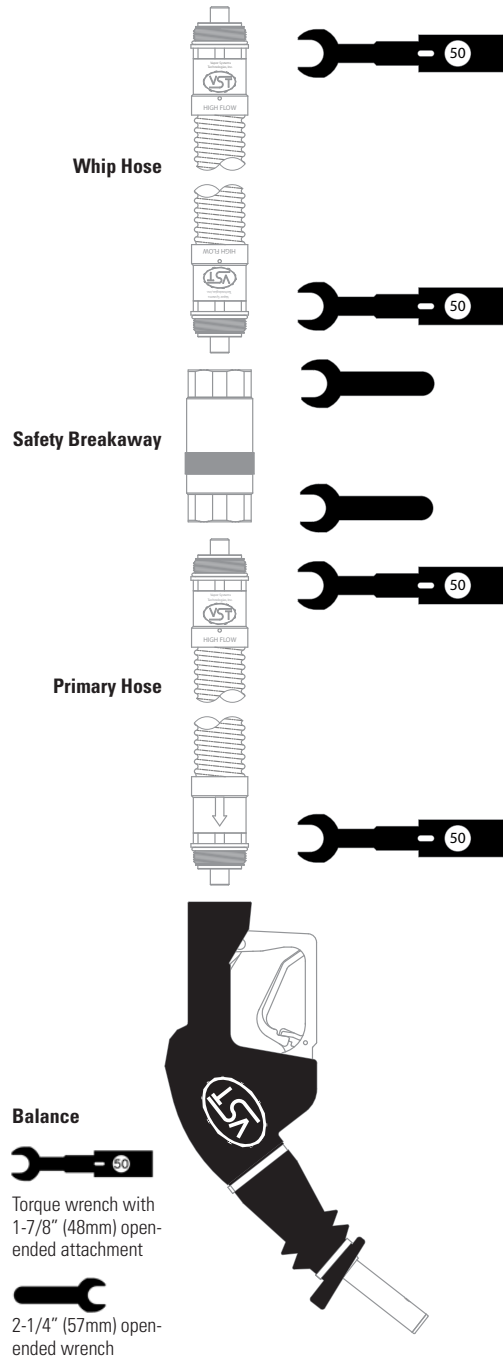

APPLICATION

These VST Safety Breakaway devices are intended to prevent damage to the dispenser and hose in the event of a vehicle drive off. These devices separate at pull forces up to 350 lbs. Determine that 350 lbs. of pull force will not damage the dispenser. After verifying that the dispenser is securely bolted to the island, it can be tested by using a spring scale and a length of rope. The rope must be connected at the dispenser outlet casting, which may require a threaded bushing with a hole for attaching the rope. Attach the scale to the rope and pull to 350 lbs. in several directions. Be sure to avoid damaging the dispenser.

NOTE

- The whip hose ALWAYS attaches to the dispenser. If a retractor is being used, the retractor clamp MUST be between the breakaway and the dispenser.
- VST hoses are made to withstand 350 pounds tensile pull without damage. If another brand of hose is present at the dispenser, VST recommends that you contact the hose manufacturer regarding the compatibility with this breakaway device.

GENERAL INFORMATION

If hanging hardware components are involved in a drive-off or incur other customer abuse, each individual component must be functionally tested prior to customer dispensing activities.

INSTALLATION PREPARATION

This procedure must be followed to insure leak-proof installation and operation of these safety breakaway products.

- Turn off and tag the power to the dispenser. Dispenser must be de-energized prior to service to avoid personal injury.
- Barricade work area to block vehicle access to the dispenser.
- Close the dispenser shear valve prior to removing hanging hardware (hoses, safety breakaways, and nozzles).
- Drain liquid product from the hanging hardware set into an approved container prior to replacing any hanging hardware components.
- Remove hanging hardware from the dispenser prior to making replacement component assembly connections. VST recommends connecting the whip hose to the dispenser as the last connection during the hanging hardware assembly

VST Installation Procedure for Phase II Coaxial EVR Balance Safety Breakaway Devices

NON-Reattachable Breakaway Part Number Series: VSTA-EVR



Vapor Systems Technologies, Inc.

650 Pleasant Valley Drive
Springboro, Ohio 45066 (USA)

Toll Free: 1-888-878-4673

Phone: 937-704-9333

Fax: 937-704-9443

www.vsthose.com

INSTALLATION AND FUNCTION TESTS

1. Initial inspection:
 - a. Carefully unpack safety breakaway from shipping carton.
 - b. Inspect safety breakaway for any damage to threads, O-Rings, exterior, etc.
2. Lightly lubricate ALL O-Rings on mating connections with petroleum jelly or other suitable lubricant. DO NOT USE pipe dope or thread sealant.
3. Attach breakaway on mating connection and tighten by hand. NOTE THE FLOW DIRECTION ARROW (where applicable). Use the hex on the breakaway body to tighten. DO NOT USE the breakaway body to tighten the unit.
4. Tighten breakaway connection to 50 foot-pounds torque. DO NOT OVER TIGHTEN. Use the hex on the breakaway body to tighten. Use a torque wrench with an open-end attachment to fit the hose couplings and an open-end wrench to properly tighten breakaway connections. DO NOT USE channel-locks or pliers to tighten connections. Proper ft./lb. torque may not be achieved with these tools.
5. Purge air from the system by pumping one-tenth (1/10) to two-tenths (2/10) of a gallon of fuel into an approved container. Inspect each hose joint connection for liquid leaks and make proper adjustments if necessary.
6. Check the nozzle shut-off action by dispensing fuel into an approved container at least three times to assure the proper automatic operation of the interlock rod. According to U/L requirement 842, the fuel flow-rate must be greater than 3 gpm for the automatic shut-off mechanism to operate.

To test, operate the nozzle and submerge the spout tip in fuel until the fuel level covers the vent hole. The main valve of the nozzle automatically shuts off when liquid covers the vent hole at the end of the spout. The nozzle is not designed to operate on gravity flow. The hold-open latch will disengage automatically when liquid covers the vent hole in the spout. Verify that the fuel flow stops when the nozzle collection sleeve is decompressed (e.g. interlock rod is disengaged). To test that the fuel flow stops, dispense some fuel into an approved container. Slowly remove the nozzle from the container while dispensing fuel. Fuel flow should stop when the nozzle collection sleeve is fully decompressed.

7. Measure the resistance between the dispenser outlet casting and the tip of the nozzle spout. Use an electronic multimeter set on the high range of the ohmmeter function. Resistance should not indicate more than 70,000 ohms per foot of hose. Example: The measured resistance for a 12-foot hose must not exceed 840,000 ohms (840 kilohms).

MAINTENANCE

Inspect safety breakaways daily for damage, loose connections or leaks. Replace as necessary. Subject to customer abuse, safety breakaway should be replaced when damaged.

The safety breakaway is designed and constructed to give lasting service if properly handled and maintained. If for any reason it should need attention, contact your VST distributor for proper disposition.

NOTE

Due to abuse, misuse, changing gasoline formulas, variation in maintenance practices, environmental conditions and/or conditions beyond the manufacturer's control, dispensing equipment may need replacement before five (5) years. Inspections and proper maintenance procedures should be followed by the station manager to determine if replacement is required before five (5) years.

WARNING

Unauthorized rebuilding or modifying of safety breakaways voids **ALL** approvals and warranties.

VST products must be used in compliance with applicable federal, state, and local laws and regulations.

VST Installation Procedure for Phase II Coaxial EVR Balance Breakaway Scuff Guards

Part Number Series: VST-BBSG-100

For Use On: VST-EVR-SBKA



Vapor Systems Technologies, Inc.

650 Pleasant Valley Drive
Springboro, Ohio 45066 (USA)

Toll Free: 1-888-878-4673

Phone: 937-704-9333

Fax: 937-704-9443

www.vsthose.com

APPLICATION

These VST Safety Breakaway scuff guards are intended for use as an optional accessory on the VST-EVR-SBKA Balance Safety Breakaways to reduce defacement of the dispenser.

Figure 1.



INSTALLATION PREPARATION

Follow all safety preparation procedures found in the VST Safety Breakaway Installation Procedure.

INSTALLATION

1. These scuff guards must be installed onto the breakaway after it has been disconnected from the hoses.
2. Slide the scuff guards onto the hose. The reduced diameter ridge of the scuff guards should be positioned for proper fit onto the ends of the breakaway.
3. Prior to sliding the scuff guard into place, re-connect and tighten breakaway, with proper torque, to the hose while the breakaway hex flats are still accessible. **See Figure 2.**
4. Slide the scuff guard over the breakaway hex flats. **See Figure 3.**

NOTE: Do not cover warning or identification labels.

Figure 2.



Figure 3.



**Permanent ID
Information:**

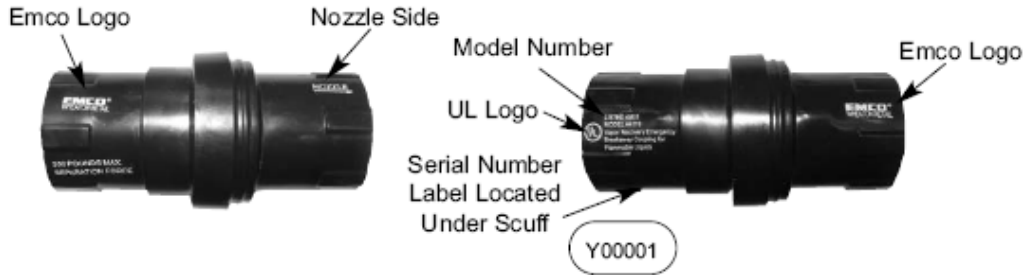

INSTALLATION INSTRUCTIONS

Service Tools Required:

- 1 7/8" Crows Foot
- Gasoline Approved Container
- Petroleum Jelly or Other Suitable Lubricant
- Torque Wrench w/ 50ft-lbs Setting
- Pipe Wrench w/ Flat Jaws

CAUTION:

1. Always barricade work area to keep pedestrians and vehicles from accessing the dispenser.
2. Always use a gasoline approved container or test can when performing any type of preventive maintenance.
3. Before attempting to install, remove or service the A4119EVR safe break valve, turn off and tag out power to the corresponding dispenser.
4. Before attempting to install, remove or service the A4119EVR safe break valve, close the emergency impact valves located inside the base of the dispenser. Relieve the line pressure and standing fuel through the nozzle spout into a gasoline approved container by compressing the bellows and squeezing the lever.
5. If a hose retractor is used, the A4119EVR safe break valve must be attached on the nozzle side of the retractor clamp.

IMPORTANT: Failure to perform cautions 3 and 4 may result in a hazardous gasoline spill, damage to equipment, personal injury and/ or death.

Pre-Inspection:

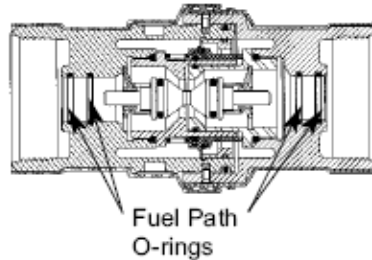

1. Carefully unpack and remove the A4119EVR safe break valve from the shipping container and evaluate for any kind of damage.
2. Verify the fuel path o-rings located on both ends of the A4119EVR safe break valve. All o-rings must be properly secured inside the factory machined grooves.

Pre-Installation:



3. Lightly lubricate the fuel path o-rings using petroleum jelly or other suitable lubricant.



4. Before attempting to install the A4119EVR safe break valve onto the whip hose, verify the word "NOZZLE", which is printed on the scuff guard of the safe break valve, is on the opposite end. Verify the vapor path o-ring is properly secured onto the connector, and in good working condition. Lightly lubricate the o-ring using petroleum jelly or other suitable lubricant.



5. Before attempting to install the A4119EVR safe break valve onto the curb hose, verify the vapor path o-ring is properly secured onto the connector, and in good working condition. Lightly lubricate the o-ring using petroleum jelly or other suitable lubricant.

IMPORTANT: Do not use pipe thread sealant compound or Teflon tape when installing the A4119EVR safe break valve. Failure to comply will void warranty.

Installation:

IMPORTANT: If this is a new facility installation, the fueling point must be flushed into a gasoline approved container before installing the A4119EVR safe break valve. Failure to perform this procedure could result in foreign material becoming lodged inside the safe break valve's fuel path causing a reduction in fuel flow.



6. Remove the scuff guard by sliding on to the whip hose. Attach the A4119EVR safe break valve onto the whip hose connector. Tighten by hand to avoid cross threading. Take caution to avoid pinching the vapor path o-ring.

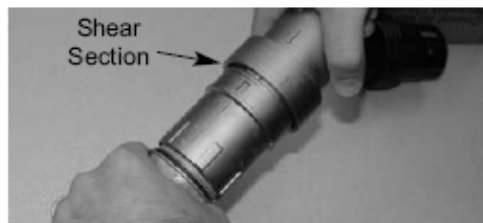

IMPORTANT: Never tighten across the shear section of the A4119EVR safe break valve. Failure to comply will result in damage to the safe break valve and void warranty.



7. Using a 1 7/8" crows foot and torque wrench, tighten the whip hose connector to 50 ft-lbs of torque.



8. Remove the scuff guard by sliding on to the curb hose. Attach the A4119EVR safe break valve onto the curb hose connector. Tighten by hand to avoid cross threading. Take caution to avoid pinching the vapor path o-ring.



9. Using a 1 7/8" crows foot and torque wrench, tighten the curb hose connector to 50 ft-lbs of torque.

Post Functional Tests:

10. Carefully purge the trapped air from the fueling point. Begin dispensing by compressing the bellows and then squeezing the lever. Dispense one gallon of fuel into a gasoline approved container.
11. Functional test the automatic shutoff of the A4005EVR nozzle. Begin dispensing by compressing the bellows and then squeezing the lever. Place the hold open latch in "high" clip position to secure the lever. Dispense one gallon of fuel into a gasoline approved container. At the same time, lower the spout tip into the standing fuel until the vent hole is completely submersed. The main valve of the A4005EVR nozzle will automatically close causing fuel flow to stop.

IMPORTANT: Perform step 11 a minimum of three times to assure the insertion interlock, hold open latch and the automatic shutoff of the A4005EVR nozzle are operating properly.

According to UL requirement 842, the fuel flow rate must be greater than 3 gallons per minute for the automatic shutoff to operate properly. A common problem cause of low flow rates are dirty or clogged dispenser filters.

Post Inspection:

12. Before placing the A4005EVR nozzle onto the dispenser cradle, inspect all hanging hardware connections for potential fuel leaks. Make proper adjustments if necessary.

PREVENTIVE MAINTENANCE

1. Weekly inspect the A4119EVR safe break valve, evaluate for any kind of damage. Damaged components must be replaced with factory authorized service kits.

<u>Part Number</u>	<u>Description</u>
494748EVR	Fuel Path O-ring Kit

2. Weekly inspect all hanging hardware connections for potential fuel leaks.

IMPORTANT: Should a drive-off or incidence of customer abuse occur, follow the initial inspection and function instructions found in the installation section.

PERFORMANCE STANDARDS & SPECIFICATIONS

This component was factory tested to, and met the following specifications:

1. Meets ARB Material Compatibility with Fuel Blends as per Section 3.8 of CP-201.
2. TP-201.2J – Complies with the maximum allowable component pressure drop of 0.04 inches of water column @ 60 CFH.

IMPORTANT: Leave these installation instructions with the station owner and/or operator.

For use with Vapor Systems
Technologies VST California Air
Resources Board Executive
Orders VR-203 and VR-204



Packing List:

(2) Fuel Path O-rings

**A4005EVR Balance
Vapor Recovery Nozzle**



**A4119EVR Coaxial
Safe Break Valve**



INSTALLATION INSTRUCTIONS

Service Tools Required:

- Pipe Wrench w/ Flat Jaws
- Bench Vise w/ 5" Jaw Width
- Petroleum Jelly or Other Suitable Lubricant
- Scribe Tool w/ 90 Degree Tip
- Gasoline Approved Container

CAUTION:

1. Always barricade work area to keep pedestrians and vehicles from accessing the dispenser.
2. Always use a gasoline approved container or test can when performing any type of preventive maintenance.
3. Before attempting to install, remove or service the A4005EVR nozzle and A4119EVR safe break valve, turn off and tag out power to the corresponding dispenser.
4. Before attempting to install, remove or service the A4005EVR nozzle and A4119EVR safe break valve, close the emergency impact valves located inside the base of the dispenser. Relieve the line pressure and standing fuel through the nozzle spout into a gasoline approved container by compressing the bellows and squeezing the lever.

IMPORTANT: Failure to perform cautions 3 and 4 may result in a hazardous gasoline spill, damage to equipment, personal injury and/or death.

Pre-Inspection:

1. Carefully unpack and remove all kitted parts from the shipping container and evaluate for any kind of damage. Verify that no parts are missing from the packing list before proceeding with the installation.

Pre-Installation:

2. Empty all standing fuel within the spout and bellows into a gasoline approved container before attempting to service the fuel path o-rings.



3. It is necessary to remove the A4005EVR nozzle and A4119EVR safe break valve from the curb hose during the removal and installation of the fuel path o-rings. Use the pipe wrench with flat jaws to loosen the curb hose connector. Unfasten the curb hose connector by hand from the A4005EVR nozzle to avoid cross threading.

IMPORTANT: Drain the fuel from the hanging hardware into a gasoline approved container when removing the A4005EVR nozzle from the curb hose.



A4005EVR Nozzle



**A4119EVR
Safe Break Valve**

4. Use the bench vise to properly secure the A4005EVR nozzle or A4119EVR safe break valve during service.

Installation:

Removing the Existing Fuel Path O-rings



A4005EVR Nozzle



**A4119EVR
Safe Break Valve**

5. Use the scribe tool to remove the existing fuel path o-rings.
6. Clean and remove all existing grease, fuel residue, debris, etc. from within the machined grooves.

IMPORTANT: Properly discard all removed components.

Installing the New Fuel Path O-rings



A4005EVR Nozzle



**A4119EVR
Safe Break Valve**

7. Use the scribe tool to install the new fuel path o-rings. Verify that both o-rings seat properly into the machined grooves.



A4005EVR Nozzle



**A4119EVR
Safe Break Valve**

8. Lightly lubricate the fuel path o-rings using petroleum jelly or other suitable lubricant.

Post-Installation:

9. Before attempting to reinstall the A4005EVR nozzle or A4119EVR safe break valve, please refer to the following installation instructions below.

- A4005EVR Balance Vapor Recovery Nozzle p/n 570435
- A4119EVR Coaxial Safe Break Valve p/n 569043

PREVENTIVE MAINTENANCE

1. Weekly inspect the A4005EVR nozzle and A4119EVR safe break valve connections for leaks or fuel residue. Replace with factory authorized service kits.

<u>Part Number</u>	<u>Description</u>
494748EVR	Fuel Path O-ring Kit

PERFORMANCE STANDARDS & SPECIFICATIONS

This component was factory tested to, and met the following specifications:

1. Meets ARB Material Compatibility with Fuel Blends as per Section 3.8 of CP-201.

IMPORTANT: Leave these installation instructions with the station owner and/ or operator.

66CLP BALANCED BREAKAWAY

ACOPLAMIENTOS DE SEGURIDAD EQUILIBRADOS TIPO "BREAKAWAY" 66CLP

IMPORTANT SAFEGUARDS

- For your protection, please read these safety instructions completely before installing and operating this equipment.
- Keep this manual on file for future reference.
- This manual contains material that may be required by authorities having jurisdiction to be on site at all times.
- Carefully observe all warnings, precautions and instructions for this equipment and in the operating instructions and adhere to them.



MEDIDAS PREVENTIVAS IMPORTANTES

- Para su protección, lea completamente estas instrucciones de seguridad antes de instalar y operar este equipo.
- Mantenga archivado este manual para futuras consultas.
- Las autoridades con jurisdicción pueden exigir que el material de este manual esté in situ en todo momento.
- Observe y cumpla cuidadosamente todas las advertencias, precauciones e instrucciones de este equipo, y siga las instrucciones para el funcionamiento del equipo.



**THIS MANUAL MUST BE LEFT WITH FACILITY MANAGEMENT
 ESTE MANUAL DEBE ESTAR EN POSESIÓN DEL ENCARGADO DE LA INSTALACIÓN**

WARNINGS & INSTRUCTIONS/ADVERTENCIAS E INSTRUCCIONES Page/Página 2

INSTALLATION/INSTALACIÓN Pages/Páginas 2

DRIVE OFF PROCEDURE/PROCEDIMIENTO DE PUESTA EN MARCHAPages/Páginas 3-5

MAINTENANCE/MANTENIMIENTO Page/Página 6

SITE NAME: NOMBRE DEL SITIO: _____	
ADDRESS: DIRECCIÓN: _____	
SERIAL NUMBER OR BREAKAWAY: NÚMERO DE SERIE DE O BREAKAWAY: _____	
DATE OF INSTALLATION: FECHA DE INSTALACIÓN: _____	
CONTRACTOR IN CHARGE OF THE FACILITY: _____	
CONTRATISTA A CARGO DE LA INSTALACIÓN: _____	

Please visit OPW's website: www.opwglobal.com for further information or contact OPW Customer Service at 1-800-422-2525 (US)
 Visite el sitio web de OPW: www.opwglobal.com para más información o comuníquese con el Servicio al Cliente de OPW al 1-800-422-2525 (EE. UU.)

	⚠ WARNING
	<p>Failure to comply with the following warnings could result in property damage, injury or death.</p>
	<p style="text-align: center;">Fire Hazard</p> <p>Do not use power tools (Class I Division I and Class I Division II) during installation process and maintenance of equipment.</p>
	<p style="text-align: center;">Chemical Exposure Hazard</p> <p>Always wear appropriate safety equipment during installation or maintenance of equipment.</p>
<p style="text-align: center;">Fire Hazard</p> <p>Do not install an unlisted ad/billboard or other unlisted after-market device on any automatic nozzle. Doing so may change the sensitivity of the shut-off mechanism. Nozzle may not shut off, causing a fuel spill. Reference: sensitivity test per Underwriters Laboratories specification UL842.</p>	

	⚠ ADVERTENCIA
	<p>El incumplimiento de las siguientes advertencias puede provocar daños a la propiedad, lesiones e incluso la muerte.</p>
	<p style="text-align: center;">Peligro de incendio</p> <p>No utilice herramientas eléctricas (Clase I División I y Clase I División II) durante el proceso de instalación y mantenimiento del equipo.</p>
	<p style="text-align: center;">Peligro de exposición a sustancias químicas</p> <p>Use siempre equipo de seguridad adecuado durante la instalación o el mantenimiento del equipo.</p>
<p style="text-align: center;">Peligro de incendio</p> <p>No instale anuncios, carteleras ni dispositivos accesorios no autorizados en ninguna pistola surtidora automática. Si lo hace puede cambiar la sensibilidad del mecanismo de cierre. La pistola podría no cerrarse y provocar un derrame de combustible. Consultar: prueba de sensibilidad según la especificación UL842 de Underwriters Laboratories.</p>	

WARNINGS



- Dispensing system must be tested to determine if a maximum separation force of 350 pounds would damage it.
- Dispenser must be securely attached to the dispensing island.
- Keep gasoline away from your eyes and skin.
- Keep gasoline out of reach of children.

PREPARATION AND TEST

- Attach a spring scale to the location where the breakaway will be installed (see FIG 1).
- Apply a 350 pound pull-force at various angles to the dispenser.
- Check emergency valves, dispenser, and hose assemblies for damage.
- If there is no damage, the installation is ready for breakaways.

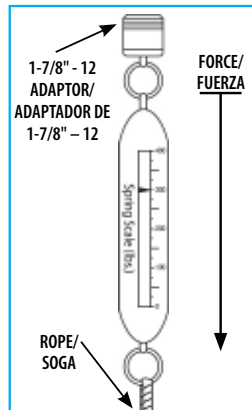

Figure 1/Figura 1

INSTALLATION – HIGH HOSE MPD

- Orient breakaway based on flow arrow on outside cover.
- Install breakaway into whip hose from the dispenser first (see FIG 2).
- Use flats at top of breakaway to tighten.
- Tighten breakaway connection to 50 foot-pounds torque.
- Install long hose into bottom of breakaway.
- Use flats at bottom of breakaway to tighten.
- Tighten breakaway connection to 50 foot-pounds torque.
- Do not wrench across the body of the breakaway.
- Do not over-tighten.
- If a separation occurs, see reconnection section on page 3.

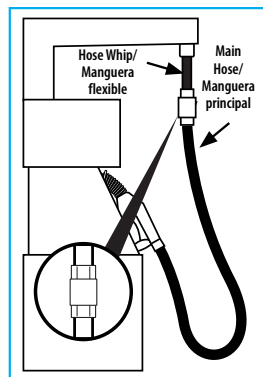

Figure 2/Figura 2

ADVERTENCIAS

- El sistema de provisión debe comprobarse para determinar si una máxima fuerza de separación de 350 libras le ocasionaría daños.
- El surtidor deberá estar conectado firmemente a la plataforma de provisión.
- Mantenga la gasolina lejos de los ojos y la piel.
- Mantenga la gasolina fuera del alcance de los niños.

PREPARACIÓN Y PRUEBA

- Conecte una báscula a resorte en el lugar en donde se instalará el acoplamiento de seguridad tipo “breakaway” (consulte la FIG. 1).
- Aplique una fuerza de tracción de 350 libras a diversos ángulos al surtidor.
- Revise las válvulas de emergencia, el surtidor y los conjuntos de mangueras en busca de daños.
- Si no hay daños, la instalación está lista para la colocación de los acoplamientos de seguridad.

INSTALACIÓN – ALTO MPD DE LA MANGUERA

- Oriente el acoplamiento de seguridad tipo “breakaway” según la flecha de flujo sobre la cubierta externa.
- Instale el acoplamiento de seguridad tipo “breakaway” en la manguera flexible primero desde el surtidor (consulte la FIG. 2).
- Utilice las piezas planas en la parte superior del acoplamiento de seguridad tipo “breakaway” para apretarlo.
- Apriete la conexión del acoplamiento de seguridad tipo “breakaway” hasta una torsión de 50 pies-libras.
- Instale la manguera larga en la parte inferior del acoplamiento de seguridad tipo “breakaway”.
- Utilice las piezas planas en la parte inferior del acoplamiento de seguridad tipo “breakaway” para apretarlo.
- Apriete la conexión del acoplamiento de seguridad tipo “breakaway” hasta una torsión de 50 pies-libras.
- No apriete con llave el cuerpo del acoplamiento de seguridad tipo “breakaway”.
- No apriete demasiado.
- Si se produce una separación, consulte la sección de reconexión en la página 3.

The following maintenance may be performed by the GDF owner/operator or any authorized service contractor

El siguiente mantenimiento puede ser realizado por el propietario/operador del GDF o por cualquier contratista de servicio autorizado



WARNING

It will require at least 40-50 lbs. of effort to re-connect the breakaway. An optional clamping tool is available (purchased separately) to make the re-connection process easier. If you have any questions or concerns, STOP and contact an authorized service contractor.



ADVERTENCIA

Se requerirán al menos 40-50 lbs. de esfuerzo para reconectar el acoplamiento de seguridad tipo "breakaway". Se dispone de una herramienta opcional de apriete (se compra por separado) para facilitar el proceso de reconexión. Si tiene preguntas o inquietudes, DETÉNGASE y póngase en contacto con un contratista de servicio autorizado.



WARNING

Some residual pressure may be present on the dispenser side of the separated breakaway – use caution when removing. A small amount of gasoline may leak out of the connection – a towel wrapped loosely around the breakaway can help minimize fuel spills.



ADVERTENCIA

Puede haber alguna presión residual del lado del surtidor del acoplamiento de seguridad tipo "breakaway" separado – tenga cuidado al desmontarlo. Puede haber fugas de una pequeña cantidad de gasolina en la conexión – una toalla envuelta de manera floja alrededor del acoplamiento de seguridad tipo "breakaway" puede ayudar a minimizar los derrames de combustible.

BREAKAWAY RECONNECTION PROCEDURE

PROCEDIMIENTO DE RECONEXIÓN DEL ACOPLAMIENTO DE SEGURIDAD TIPO "BREAKAWAY"

1. Verify the dispenser is not authorized/activated.
2. Remove both halves of the breakaway from the hose.
3. Perform visual inspection of the breakaway body components.
 - a. If the "Spud" assembly (see FIG 3, page 4) is damaged beyond repair, the entire breakaway will need to be replaced.
 - b. If the "Body" assembly (see FIG 3, page 4) is damaged beyond repair, the entire breakaway must be replaced.
 - c. Ensure the "spring" is not damaged or missing (see FIG 3, page 4).
4. Replace damaged and missing breakaway components.
 - a. The O-ring will need to be replaced every time breakaway separation occurs, replace with part number 204870.
 - b. If the Spring is damaged (or missing), replace with part number 204872.
 - c. If the Plastic Sleeve is damaged, replace with part number 204811.

1. Verifique que el surtidor no esté autorizado/activado.
2. Desmonte ambas mitades del acoplamiento de seguridad tipo "breakaway" de la manguera.
3. Realice una inspección visual de los componentes del cuerpo del acoplamiento de seguridad tipo "breakaway".
 - a. Si el ensamble con el "relieve" (consulte la FIG. 3, página 4) está dañado sin posibilidad de reparación, deberá reemplazarse todo el acoplamiento de seguridad tipo "breakaway".
 - b. Si el ensamble con el "cuerpo" (consulte la FIG. 3, página 4) está dañado sin posibilidad de reparación, deberá reemplazarse todo el acoplamiento de seguridad tipo "breakaway".
 - c. Asegúrese de que el "muelle" no esté dañado o falte (consulte la FIG. 3, página 4).
4. Reemplace los componentes dañados o faltantes del acoplamiento de seguridad tipo "breakaway".
 - a. El aro tórico deberá reemplazarse cada vez que ocurra una separación del acoplamiento de seguridad tipo "breakaway", reemplace con el número de pieza 204870.
 - b. Si el muelle está dañado (o falta), reemplace con el número de pieza 204872.
 - c. Si el manguito plástico está dañado, reemplace con el número de pieza 204811.

5. Re-connection procedure:

- a. Lubricate the O-ring with petroleum jelly or silicone grease.
 - b. Push the "spud" into the "body" by applying increasing force while wiggling the "spud" in a rotating motion until it enters the spring in the "body".
 - c. Align the pins with slots and continue pushing the "spud" into the "body" until they latch together. The pins should be in the bottom of the slot. See "connected" picture in FIG 3.
 - d. Use a ratchet style one-handed bar clamp such as Bessey part number DU030-8 (Grainger part number 6XE60) or equivalent to compress the two halves together (see FIG 4).
6. Reinstall the breakaway onto the hose ends, making sure that the arrow on the label is pointing toward the nozzle.
7. Authorize the dispenser and perform functional testing, refer to VST IOM 5.

5. Procedimiento de reconexión::

- a. Lubrique el aro tórico con vaselina o grasa silicónica.
 - b. Empuje el "relieve" en el "cuerpo" aplicando una fuerza creciente mientras desplaza suavemente el "relieve" con un movimiento rotativo hasta que ingrese el muelle en el interior del "cuerpo".
 - c. Alinee los pasadores con las ranuras y continúe empujando el "relieve" al interior del "cuerpo" hasta que se enganchen entre sí. Los pasadores deben llegar al fondo de la ranura. Consulte la ilustración del dispositivo "conectado" en la FIG. 3.
 - d. Utilice una abrazadera de barra de tipo trinquete, de uso con una mano, tal como el número de pieza de Bessey DU030-8 (número de pieza de Grainger 6XE60) o equivalente para comprimir las dos mitades entre sí (consulte la FIG. 4).
6. Vuelva a colocar el acoplamiento de seguridad tipo "breakaway" en los extremos de la manguera, asegurándose de que la flecha en la etiqueta esté orientada hacia la boquilla.
7. Autorice el surtidor y realice las pruebas funcionales; consulte VST IOM 5.

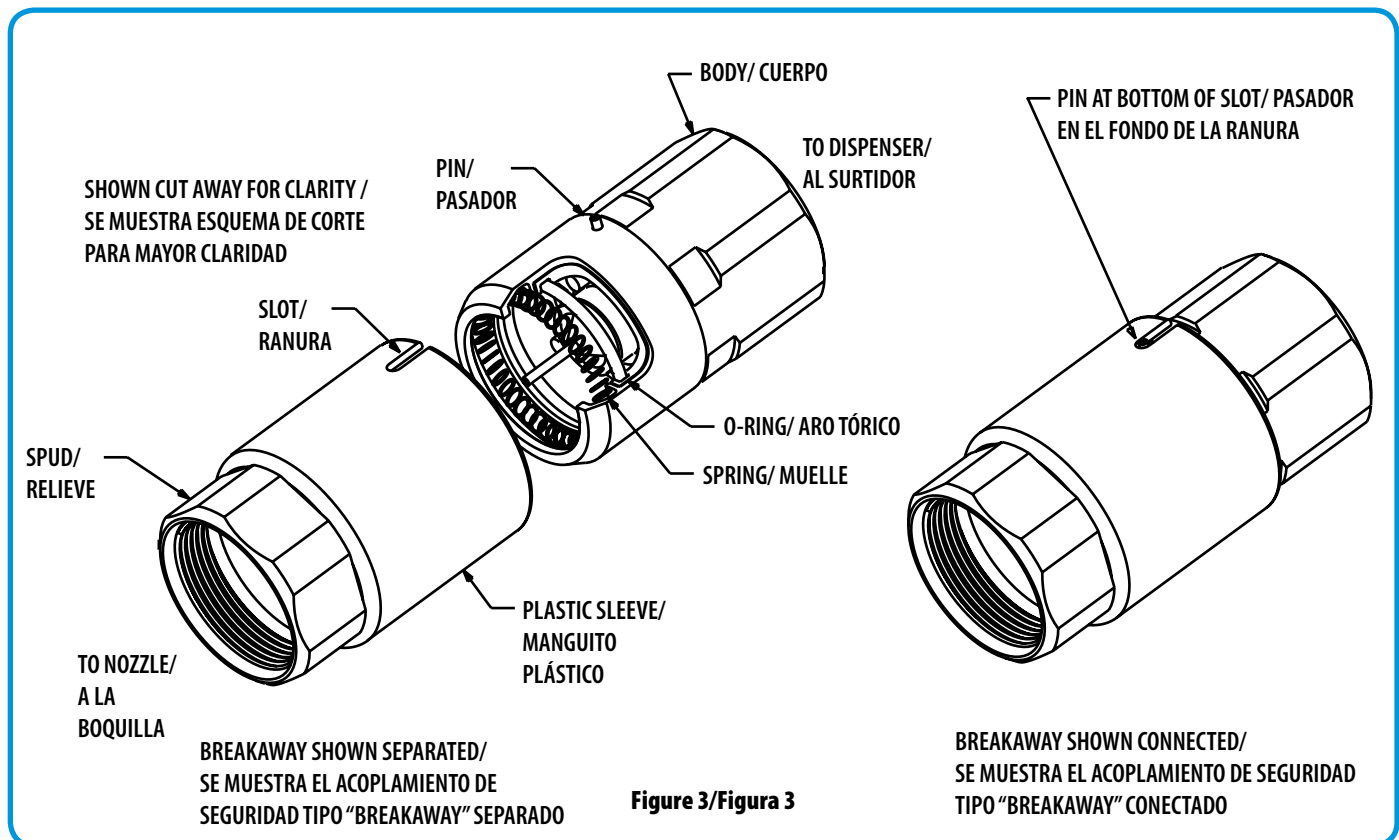

Please visit OPW's website: www.opwglobal.com for further information or contact OPW Customer Service at 1-800-422-2525 (US)
Visite el sitio web de OPW: www.opwglobal.com para más información o comuníquese con el Servicio al Cliente de OPW al 1-800-422-2525 (EE. UU.)

9-20

ARB Approved IOM 9 -EVR Balance Breakaways VR-203 and VR-204
IOM 9-EVR aprobado por ARB para acoplamientos de seguridad tipo "breakaway" equilibrados modelos VR-203 y VR-204



Figure 4/Figura 4

The following is to be completed by the individual reconnecting the breakaway:

I, _____, hereby declare that I have followed these instructions per the manufacturer's recommendations on this day _____, in the month of _____, 2012

Lo siguiente deberá ser completado por el individuo que reconecta el acoplamiento de seguridad tipo "breakaway":

Yo, _____, por este medio declaro que he seguido estas instrucciones de acuerdo con las recomendaciones del fabricante el día _____ del mes de _____ de 2012

Maintenance Log Instructions / Instrucciones del registro de mantenimiento			
<ul style="list-style-type: none"> • For each repair or product change out, complete an entry on this form. / Haga una anotación en este formulario para cada reparación o cambio de producto. • For each new alarm condition on the station's monitoring system, complete an entry on this form. / Haga una anotación en este formulario para cada condición de alarma del sistema de supervisión de la estación. 			
<p>Repair Logs, which shall include: / Registros de reparaciones, que deben incluir:</p> <p>(i) Date and time of each repair. / Fecha y hora de cada reparación.</p> <p>(ii) The name of person(s) who performed the repair, and if applicable, the name, address and phone number of the person's employer. / Nombre de la(s) persona(s) encargada(s) de la reparación y, si corresponde, nombre, dirección y número de teléfono de la empresa.</p> <p>(iii) Description of services performed. / Descripción de los servicios realizados.</p> <p>(iv) Each component that was repaired, serviced, or removed, including the required component identification information. <i>Example: manufacturer and product serial number.</i> / Componentes reparados, revisados o retirados, incluidos los datos de identificación de cada uno de ellos. <i>Ejemplo: fabricante y número de serie del producto.</i></p>			
<p>ALL repairs should be logged! / Se deben anotar TODAS las reparaciones</p> <p>Whether the new equipment is from the station's own stock or from a maintenance company, everything should be entered into the daily repair log. / Haga todas las anotaciones necesarias en el registro diario de reparaciones, tanto si los repuestos proceden del almacén de la estación como de una empresa de mantenimiento.</p>			
Date of Problem (MM/DD/YY) / Fecha del problema (MM/DD/AA)	Description of Defect, Alarm or Spill / Descripción del defecto, la alarma o el derrame	Date/Time of Repair/Remedy (MM/DD/YY) / Fecha y hora de la reparación/intervención (MM/DD/AA)	Description of Repair or Remedy / Descripción de la reparación o intervención. Anote cada componente reparado, sustituido y/o instalado e incluya la marca, el modelo y el número de serie de los componentes antiguos y nuevos
4/1/00	Nozzle #: 3 / Pistola nº: 3 Grade of Gas: 87 / Octanaje: 87 Nozzle spout for 3-87 out of round, Called repair company on 4/1. / Pérdida de circularidad en la boquilla de la pistola 3-87, Llamada a la empresa de mantenimiento el 1/4.	4/2/00 3:30 pm	Replaced OPW 11VAI-69 nozzle serial #456789 with new OPW 11VAI-69 nozzle serial #458901. / Cambio de pistola OPW 11VAI-69 (nº serie 456789 por nueva pistola OPW 11VAI-69 (nº serie 458901).
	Nozzle #: / Pistola nº: Grade of Gas: / Octanaje:		Name/Company/Address / Who Performed the Repair / Nombre/ Empresa/Dirección / Número de teléfono de la persona encargada de la reparación Tom Smith, ABC Nozzle Co. 1111 E. Fourth Ave. La Habra, CA 560-345-6789
	Nozzle #: / Pistola nº: Grade of Gas: / Octanaje:		
	Nozzle #: / Pistola nº: Grade of Gas: / Octanaje:		

Please visit OPW's website: www.opwglobal.com for further information or contact OPW Customer Service at 1-800-422-2525 (US)
Visite el sitio web de OPW: www.opwglobal.com para más información o comuníquese con el Servicio al Cliente de OPW al 1-800-422-2525 (EE. UU.)