

Table 1: Quarterly Inspections for FFS Healy Clean Air Separator Only

Inspect Clean Air Separator for proper operating configuration. See Executive Order VR-204, Exhibit 2, Figure 2B-16 or 2B-16H for guidance. Figure 2B-16 applies to vertical CAS installations. Figure 2B-16H applies to horizontal CAS installations.

Quarterly Inspections for Healy Clean Air Separator		
Checklist results may be used to assist with filling out GDF maintenance log. This table may be also used for testing the Clean Air Separator.	Date _____	Page ____ of ____
Clean Air Separator Configuration (see Exhibit 2, Figures 2B-16 or 2B-16H)		
Valve	Circle One	
A	Open	Closed
B	Open	Closed
C	Open	Closed
D	Open	Closed
Plug	Circle One	
E	Installed	Missing
F	Installed	Missing

Table 2: Annual Inspection Requirements for VST ECS Membrane Processor:

Annual VST ECS Membrane <i>Processor</i> Inspections and Replacements					
Component	Procedure	Fail Criteria	Corrective Action	Reference Manuals	Authorized Personnel
Blower	Replace the blower every ten years or 15,000 hrs. (whichever comes first).			IOM - 11	VST ASC Level C
Vacuum pump	Replace pump every ten years or 15,000 hrs. (whichever comes first).				
Vacuum pump drive coupling - rubber insert	Visually inspect the drive coupling between the vacuum pump and the motor for wear	Rubber debris is found on or around the vacuum-pump base.	Replace the drive coupling rubber insert	IOM - 11	
Heat Trace Cable	Check the continuity of the heat trace cable.	If the heat trace cable circuit is open, the cable has failed.	Replace the heat- trace cable	IOM - 11	
HC Sensor	Test the HC sensor	The difference shall be within $\pm 1.0\%$ HC concentration from the calibration gas concentration for zero and mid-range gas and $\pm 2.0\%$ for the high-range gas.	Replace the HC Sensor	IOM – 11 and Exhibit 8	

Table 3: Preventative Maintenance Checklist Form for VST ECS Membrane Processor

Component	Frequency	Date Inspected	Completed	Required Action Items
VST ECS PROCESSOR	Yearly			
<ul style="list-style-type: none"> Inspect drive coupling on the vacuum pump. 			[]	
<ul style="list-style-type: none"> Check the continuity of the heat trace cable. 			[]	
RECIRCULATION BLOWER				
Replace every 10 years or 15,000 hours, whichever comes first.			[]	
VACUUM PUMP				
Replace every 10 years or 15,000 hours, whichever comes first.			[]	

Table 4: Annual Inspection Requirements/Checklist for Hirt VCS 100 Vapor Processor:

DATE OF TEST:

SERVICE COMPANY NAME	SERVICE COMPANY'S TELEPHONE	
SERVICE TECHNICIAN	HIRT TECHNICIAN CERTIFICATION # (as applicable) ICC or DISTRICT TRAINING CERTIFICATION (as applicable)	
STATION NAME	DISTRICT PERMIT #	
STATION ADDRESS	CITY	STATE ZIP
Instructions: Perform each step and check each box after step is completed. File completed checklist with station's Maintenance Records.		
1.	Turn OFF electrical power to processor. CAUTION: The processor can be hot from operation. Use caution when removing Weather Cover, Shell, and raising Inner Stack; they are HOT!	<input type="checkbox"/>
2.	Remove Weather Cover. Look inside stack and burner chamber to check for debris. Remove any debris.	<input type="checkbox"/>
3.	Remove padlocks, if any, and remove Shell from processor.	<input type="checkbox"/>
4.	Loosen stack bolt and raise Inner Stack. The pilot and igniter/sensor are now exposed. The internals should be checked for foreign material. Remove any foreign material.	<input type="checkbox"/>
5.	Check igniter/sensor for carbon buildup. Replace Pilot Tip assembly if Excessive buildup. See instructions that come with replacement Pilot Tip for Installation details.	<input type="checkbox"/>

<p>6.</p>	<p>Visually check all processor piping and tubing for leaks (this is checked when conducting TP-201.3 and Exhibit 4 of Executive Orders VR-203 and VR-204). <input type="checkbox"/></p> <p>Check metal tubing and piping for kinks, worn areas, and cracks, or deterioration. Check piping and metal tubing fittings to insure that they are strong and tight sealing. Replace any components that show any wear, cracks, or deterioration.</p>
<p>7.</p>	<p>Conduct Exhibit 13 of Executive Orders VR-203 and VR-204 “Hirt VCS 100 Process With Indicator Panel Operability Test Procedure” <input type="checkbox"/></p>
<p>8.</p>	<p>Check setting of Pilot Needle Valve adjustmet (section 8.8 of Hirt VCS 100 IOM). <input type="checkbox"/></p>
<p>9.</p>	<p>Lower Inner Stack and Tighten bolt. Replace Shell, Weather Cover, and padlocks removed for visual inspection. <input type="checkbox"/></p>
<p>10.</p>	<p>Verify handle on 3-way valve is in down position – Processor to UST Ullage. <input type="checkbox"/></p>
<p>11.</p>	<p>Turn ON electrical power to processor. <input type="checkbox"/></p>

Table 5: Annual battery check for Veeder-Root wireless components

You can get the battery status from the TLS-350 (with software Version 30A or higher). The battery status is displayed for the wireless sensors from the Smart Sensor Diagnostics (see menu below). The wireless sensors' battery status can also be printed from this screen. The battery status for the wireless sensors is reported as Full, Medium, Low, or Replace.

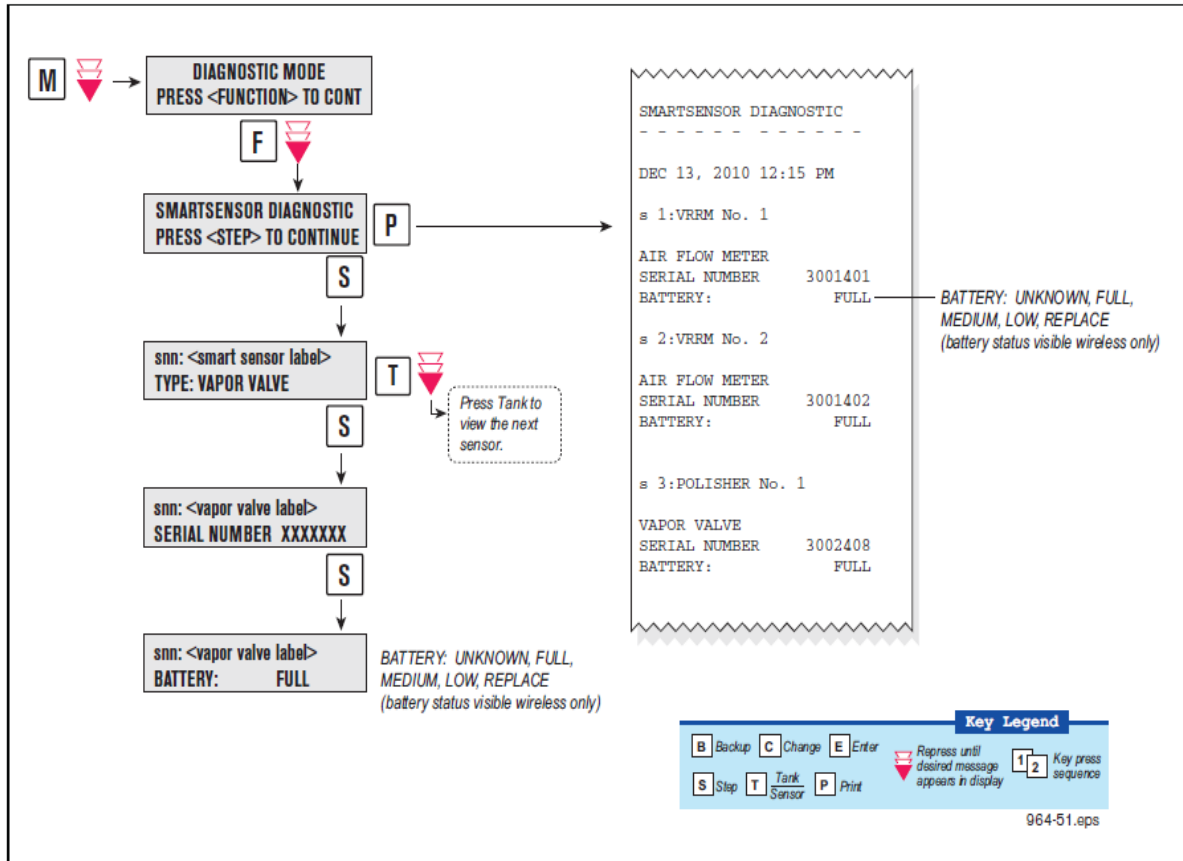

Figure 24. Device Battery Status in SmartSensor Diagnostic Menu

VR-203 and VR-204 Annual Battery Check for Veeder-Root Wireless Sensors						
						Date: _____
Vapor Valve	Pressure Sensor	Flow Meter	Battery Status			
			Full	Medium	Low	Replace

Table 6: Annual Inspection Requirements for VST Green Machine Processor:

Annual <i>Green Machine</i> Inspections					
Component	Procedure	Fail Criteria	Corrective Action	Reference Manual	Authorized Personnel
Vacuum Pump Drive Coupling - Rubber Insert	Visually inspect the Drive Coupling between the Vacuum Pump and the Motor for wear	Rubber debris is found on or around the Vacuum Pump base.	Replace the drive coupling rubber insert	IOM-18	VST ASC Level D
Vacuum Pump	Replace pump every 10 years or 15,000 hours			IOM-18	
VST <i>Green Machine</i> Annual Compliance Testing	Exhibit 15	<p><u>Compliance Bag Test:</u> If the value of the NOVA reading is $\geq 17\%$, the <i>Green Machine</i> is not in compliance.</p> <p><u>Continuous Monitoring Test:</u> If a motor fault is not found then the <i>Green Machine</i> is not in compliance</p>	Refer to the Green Machine Troubleshooting Manual for maintenance	Exhibit 15	